

## FEATURES

The 2-way ball-valve 799 Z+AP-RE is designed for the shut-off of HP hydraulic networks up to 315 or 420 bars, according to the diameters. POM floating ball and seat. The valve is EC- and ATEX-approved. The ISO 5211 mounting pad allows you to mount the actuator with a stainless steel yoke. The pneumatic motorisation is available in double and spring-return with numerous options.

## AVAILABLE MODELS

**799 ZA:** 2-way carbon steel.

**799 ZI:** 2-way stainless steel.

3/8" to 1" diameters.

G threaded connections according to ISO 228.

Double and spring-return actuators.



## LIMITS OF USE

<b>Fluid pressure: PS</b>	see table below
<b>Fluid temperature: WT°</b>	- 20°C / +100°C
<b>Ambient temperature</b>	- 20°C / + 80°C
<b>Motor compressed air</b>	mini 6 bar / maxi 10 bar

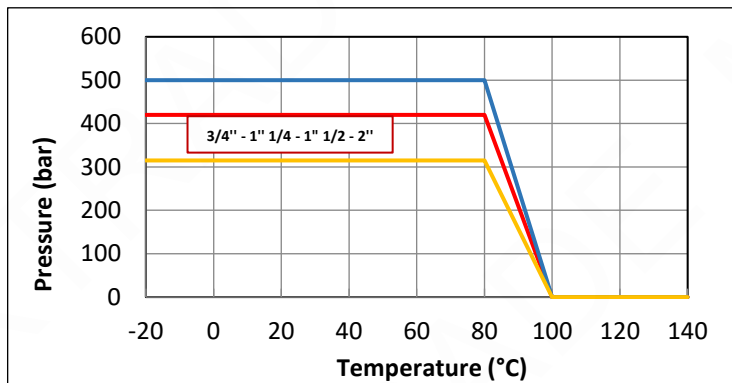

DN	3/8"	1/2"	3/4"	1"	1" 1/4	1" 1/2	2"
WP (bar)	500	500	420	315	420	420	420

## DIRECTIVES AND MANUFACTURING STANDARDS

OBJECT	Standard	ON	OBJECT	Standard
Pressure Equipment Directive 2014/68/EC	1/4" to 1": not subject		Connection Motorisation	ISO 5211:
	1" 1/4 to 2": category IV	TÜV 0034	Actuator pilot connection	NAMUR
ATEX Directive	II 2G c Tx zones 1 and 2	TÜV 0034	Switch box connection	VDI/VDE 3845
	EN 13463-1 and 5		SIL 3 level (the actuator alone)	EN 61508
Motorisation yoke	EN 15081		Actuator	EN 15714-3

**CONSTRUCTION**

No.	Name	799 ZA materials - steel	799 ZI materials - stainless steel
1	Body	1.0715 carbon steel	1.4401 SS
2	Ball	1.0715 carbon steel	1.4401 SS
3	Stem	1.0715 carbon steel	1.4401 SS
4	Seats	POM	POM
5	O-ring	FPM	FPM

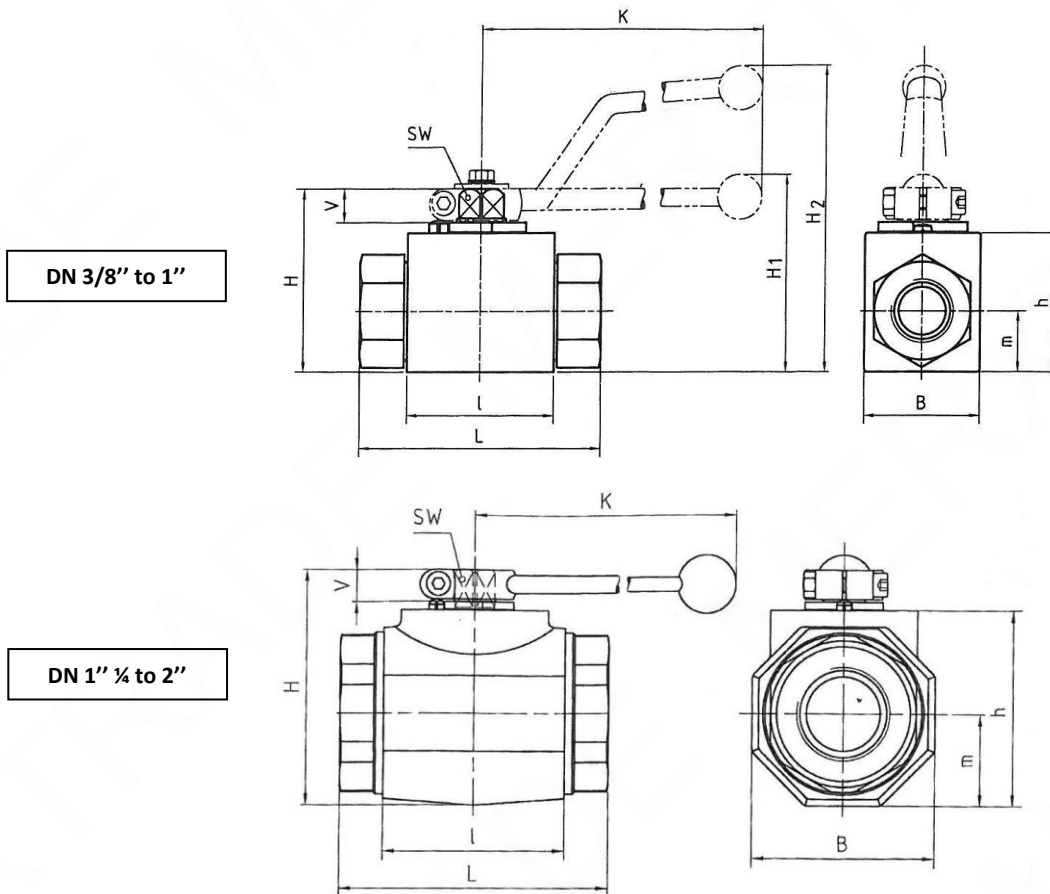

**DIMENSIONS (mm)**

DN	3/8"	1/2"	3/4"	1"	1 1/4"	1 1/2"	2"
L	72	83	95	113	111	130	140
I	43	48	62	66	80	85	100
B	32	35	49	58	81	100	118
H	52	54	75	83	107	124	138
h	38	40	57	65	86	103	117
m	17.5	19	24.5	29.5	40.5	50	59
V	11	11	14	14	16.5	16.5	16.5
SW	9	9	14	14	17	17	17
K	115	115	200	200	320	320	320
i	14	16.3	18	20	22	24	26

### AP-RE PNEUMATIC MOTORISATION

The ALPHAIR motorisation proposed as standard comprises:

- a safety coefficient of 1.3 minimum compared to the nominal torque of the valve.
- 6 bar air non-lubricated dry motor.
- an upstream / downstream pressure difference  $\Delta P=100$  bar max.

The actuator mount is a yoke + driver according to the EN 15081 standard.

DN	Double-effect	V (litres)	Time (s)*	Single-effect	V (litres)	Time (s)*
3/8"	RE 64	0.45	1	RES 76/6	0.61	1
1/2"	RE 64	0.45	1	RES 86/6	0.98	1
3/4"	RE 76	0.61	1	RES 101/6	1.8	2
1"	RE 76	0.61	1	RES 101/6	1.8	2

For any other operating conditions, please contact us.

\* indicative time for actuator running empty

### MOTORISATION OPTIONS

There are many options, so please contact our sales service for more information on these:

1	actuators dimensioned for a compressed air pressure of 3, 4 or 5 bar	
2	actuator dimensioned for an upstream / downstream pressure difference $\Delta P$ greater than 10 bar	
3	actuator with special coating, stainless steel actuator	
4	Actuator for very low (-60°C) or very high (+150°C) ambient temperatures.	
5	Automatic safety valve with a reinforced safety coefficient and closing time < 1s,	
6	thermal dispersion yoke for high temperature fluids	
7	100mm high steel height adjustment for installing heat-insulation	
8	special version for ATEX zones	
9	manual override with declutchable gear box	
10	compressed air filter regulator	
11	all types of piloting solenoid valves	
12	all types of switch boxes	
13	all types of positioner	
14	quick exhaust	
15	flow-rate limiters	
16	air lock	

### INSTALLATION IN AN ATEX ZONE

For 799 Z+AP-RE automatic valves to be installed in ATEX 1 or 2 zones, this has to be specified when ordering. Our services will check of the assembly, the installation of an earthing braid, and will issue an assembly certificate. Our authorised technicians carry out these operations in the workshop. Please contact us.

The special assembly and maintenance instructions for motorised valves in the ATEX zones must be followed.

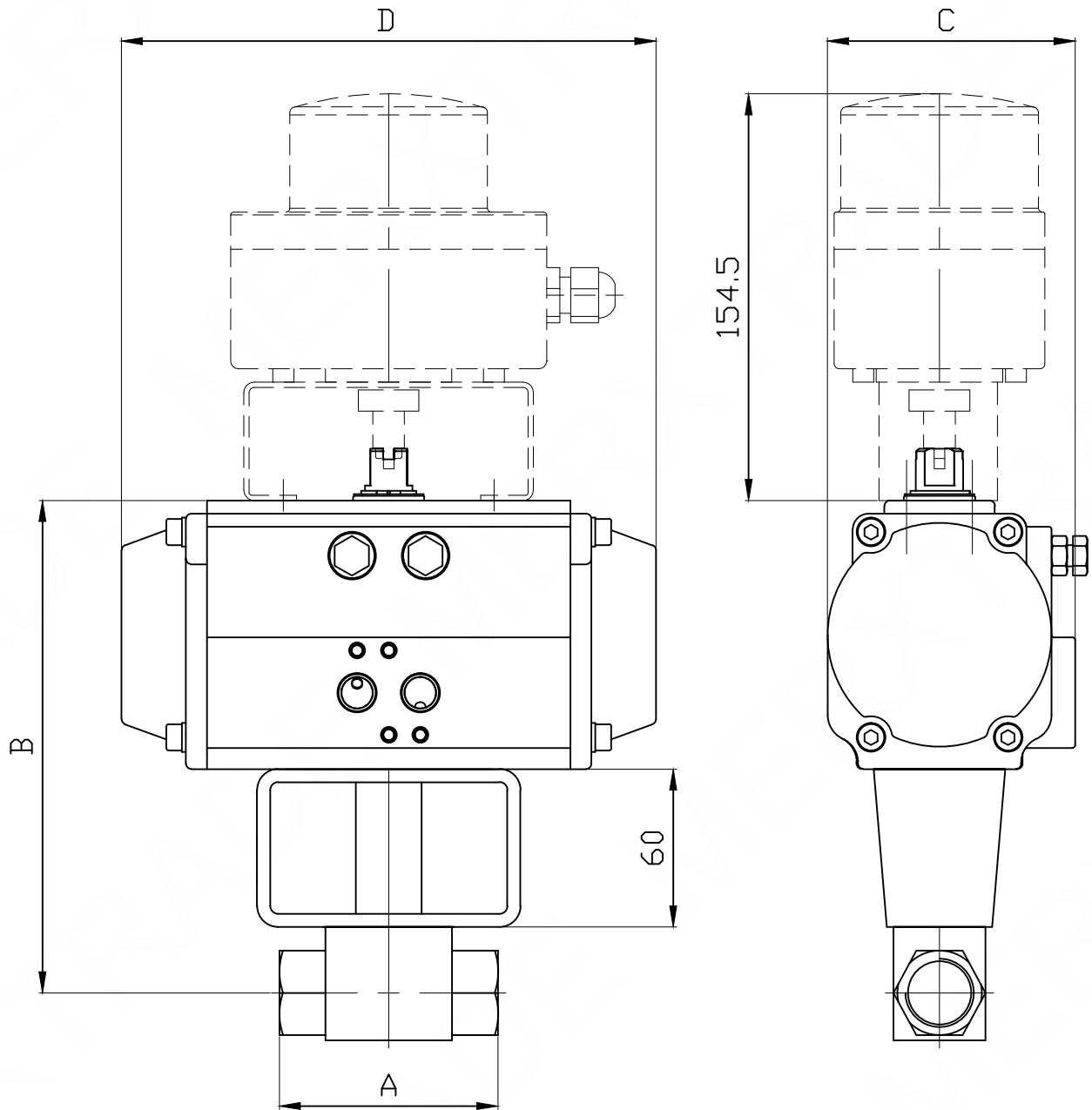

DN	3/8"		1/2"		3/4"		1"	
ALPHAIR	RE64	RES76	RE64	RES86	RE76	RES101	RE76	RES101
A	72		83		95		113	
B	166.5	182.5	167	193	194.5	219.5	197.5	222.5
C	86	94	86	104	94	127	94	127
D	155	203	155	203	203	261	203	261
KG	2.73	4.34	2.85	5.85	5.06	8.89	5.85	9.61



# RE SERIES

**PNEUMATIC ACTUATORS  
WITH EXTERNAL ADJUSTMENT**

**ROTATION 90°**



**Alphaair**



English edition

# ALPHAIR PNEUMATIC ACTUATORS EXTERNAL ADJUSTMENT

## New "RE" SERIES

Merxtrade B.V.

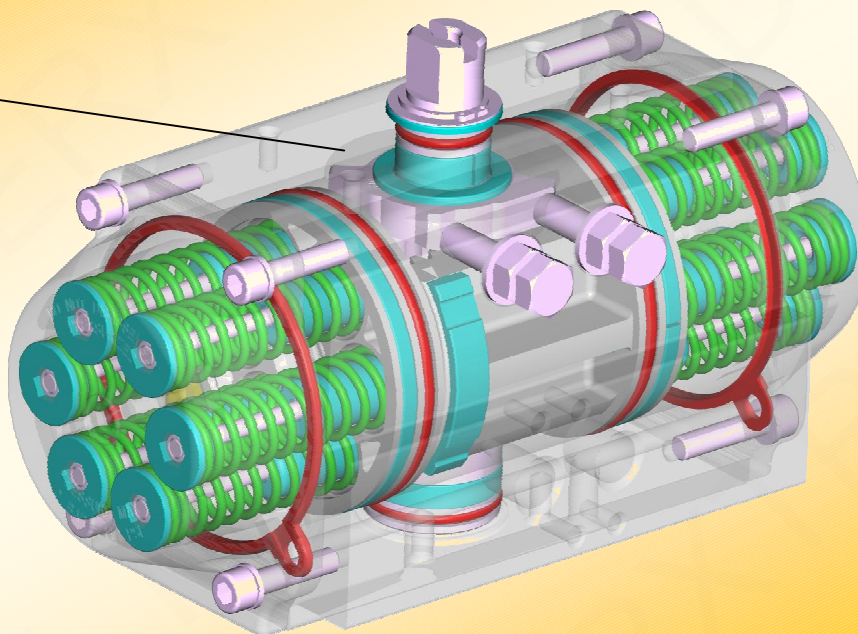
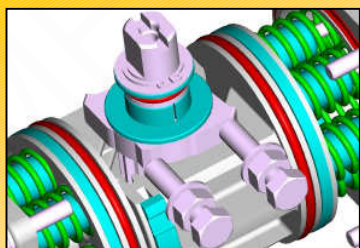

The new series of ALPHAIR Pneumatic Actuators with special "External Adjustment" system meets every quality and precision requirement.

The new "External Adjustment" system guarantees maximum precision on rotation adjusting, for normal and heavy conditions, in any application field.

Suitable for every requirement, ALPHAIR Pneumatic Actuators with special "External Adjustment" system are carefully designed for maximum torque rating and maximum lifetime.

More compact, heavy and reliable, ALPHAIR Pneumatic Actuators with special "External Adjustment" system can be easily assembled on every kind of valve.

### STANDARD VERSION FEATURES

- **EN AW 6063 extruded aluminium Body**, inside surface finishing Ra= 0,4-0,6. 25 µ Hard Anodizing.
- **EN AB 46100 die-cast aluminium alloy Pistons**, 15 micron Anodizing.
- **EN AB 46100 die-cast aluminium alloy Covers**, painted with 60-80 µ polyester powder.
- **Carbon steel Shaft**, 20 µ nickel-plated. Stainless Steel AISI 304 (A2) or AISI 316 (A4) as Optional.
- **External adjusting gear, made of Stainless Steel AISI 316 (A4).**
- **AISI 316 (A4) Stainless Steel Screws.**
- **NBR nitrile nubber seals.** FPM/FKM or SILICONE on request.
- Acetalic resin + 20% PTFE bearings, for low friction, easily replaceable for maintenance. PA66 or LEXAN on request.
- Pre-compressed Spring Cartridges, easily replaceable for maintenance, 60-80 micron polyester painted.
- High performances Syntetic Grease as standard grease. Special grease supplied for HIGH/LOW/VERY LOW temperatures.
- Several special protections available for chemical, pharmaceutical, food and industrial environments.
- Rotation adjustment  $\pm 5^\circ$  in both opening and closing position. Assembly precision  $\pm 1^\circ$ , made by electronic devices.
- Double lower drilling for valve fastening and centering, according to ISO 5211-DIN 3337 Standards.
- Double square lower female shaft key (starlike), according to ISO 5211-DIN 3337 Standards for assembly on valves with square key on line ( $0^\circ$ ) and diagonal key ( $45^\circ$ ).
- Solenoid connections according to NAMUR VDI\VDE-3845 Standards.
- Top drilling for accessories fastening, and upper shaft end according to NAMUR VDI\VDE-3845 Standards.
- Position indicator on request, enabling switch-box assembly on top.
- Aluminium adhesive nameplates, with progressive serial number punched.
- Lubrication carried out by the manufacturer, guaranteed for min. 1.000.000 operations.
- Running test and 100% seal test carried out with electronic equipment and certification of every individual product.
- Standard execution for temperatures from  $-20^\circ\text{C}$  to  $+80^\circ\text{C}$  (optional, special execution for extreme temperatures).
- Conformity for use in explosive environment; Ex II 2 GD "c" protection type.
- According to EN 15714-3 design and manufacture standard requirements.

FEEDING	TEMPERATURE RANGE	SUPPLY PRESSURE	ROT. ADJUSTMENT
Dry or lubricated 50 um filtered compressed air	Standard $-20^\circ +80^\circ\text{C}$ ( $-4 +175^\circ\text{F}$ ) HIGH Temperature $-20^\circ +150^\circ\text{C}$ ( $-4 +300^\circ\text{F}$ ) LOW Temperature $-40^\circ +80^\circ\text{C}$ ( $-40 +175^\circ\text{F}$ ) VERY LOW Temperature $-60^\circ +$ <a href="http://www.merxtrade.com">www.merxtrade.com</a>	8 bar/120 psi Continuous working - 10 bar/142 psi MAXIMUM	$\pm 5^\circ$ in both OPENING and CLOSING position

Information provided as an indication and subject to possible modification Colours and details can be different then shown in data sheets or pictures

Merxtrade BV has no liability for any damages by use off any information displayed on these pages.

## DOUBLE ACTING TORQUES IN Nm

TYPE	AIR SUPPLY PRESSURE (bar)									
	1	2	3	4	5	6	7	8	9	10
RE 043	-	-	6,5	8,7	10,9	13,0	15,2	17,3	19,5	21,7
RE 051	3,3	6,7	10,0	13,4	16,7	20,1	23,4	26,8	30,1	33,5
RE 064	5,9	11,8	17,8	23,7	29,6	35,5	41,4	47,4	53,3	59,2
RE 076	11,8	23,5	35,3	47,1	58,9	70,6	82,4	94,2	105,9	117,7
RE 086	17,2	34,5	51,7	68,9	86,1	103,4	120,6	137,8	155,0	172,3
RE 101	27,5	54,9	82,4	109,8	137,3	164,8	192,2	219,7	247,1	274,6
RE 116	43,7	87,4	131,1	174,9	218,6	262,3	306,0	349,7	393,4	437,1
RE 126	56,6	113,3	169,9	226,5	283,2	339,8	396,4	453,0	509,7	566,3
RE 146	88,4	176,7	265,1	353,4	441,8	530,1	618,5	706,9	795,2	883,6
RE 161	114,9	229,7	344,6	459,5	574,3	689,2	804,1	918,9	1034	1149
RE 181	156,6	313,1	469,7	626,3	782,9	939,4	1096	1253	1409	1565
RE 201	215,3	430,6	646,0	861,3	1077	1292	1507	1723	1938	2153
RE 241	372,5	745,0	1118	1490	1863	2235	2608	2980	3353	3725
RE 271	539,2	1078	1617	2157	2696	3235	3774	4314	4853	5392
RE 331	911,5	1823	2734	3646	4558	5469	6385	7292	8204	9115
RE 421	1671	3342	5013	6684	8354	10025	11696	13367	-	-

## SINGLE ACTING TORQUES IN Nm

TYPE	SPRING SET	AIR SUPPLY PRESSURE (bar)												SPRING TORQUE	
		3		4		5		6		7		8		90°	0°
		0°	90°	0°	90°	0°	90°	0°	90°	0°	90°	0°	90°		
RE 043	SR 3/3 SR 4/4	-	-	-	-	7,1	4,1	9,3	6,3	11,5	8,5	13,7	10,7	6,8	3,8
RE 051	SR 3/3	5,8	4,3	9,1	7,6	12,5	10,9	15,8	14,3	19,2	17,6	22,5	21,0	5,8	4,3
	SR 4/4	4,4	2,3	7,8	5,7	11,1	9,0	14,4	12,3	17,8	15,7	21,1	19,0	7,8	5,7
	SR 5/5			6,3	3,7	9,7	7,1	13,0	10,4	16,4	13,8	19,7	17,1	9,7	7,1
	SR 6/6			8,2	5,1	11,6	8,5	14,9	11,8	18,3	15,2	21,6	18,5	11,6	8,5
RE 064	SR 3/3	10,7	7,1	16,6	13,0	22,5	18,9	28,5	24,8	34,4	30,8	40,3	36,7	10,7	7,1
	SR 4/4	8,4	3,5	14,3	9,4	20,2	15,4	26,1	21,3	32,0	27,2	38,0	33,1	14,3	9,4
	SR 5/5			11,9	5,9	17,8	11,8	23,8	17,7	29,7	23,6	35,6	29,6	17,8	11,8
	SR 6/6			15,5	8,2	21,4	14,1	27,3	20,1	33,2	26,0	40,1	33,0	21,4	14,1
RE 076	SR 3/3	21,1	14,3	32,8	26,0	44,6	37,8	56,4	49,6	68,1	61,3	79,9	73,1	21,1	14,3
	SR 4/4	16,3	7,2	28,1	19,0	39,8	30,8	51,6	42,5	63,4	54,3	75,2	66,1	28,1	19,0
	SR 5/5			23,3	12,0	35,1	23,8	46,9	35,5	58,6	47,3	70,4	59,1	35,1	23,8
	SR 6/6			30,3	16,7	42,1	28,5	53,9	40,3	65,6	52,0	77,4	64,8	42,1	28,5
RE 086	SR 3/3	33,8	17,8	51,1	35,1	68,3	52,3	85,5	69,5	102,7	86,7	120,0	104,0	33,8	17,8
	SR 4/4	27,9	6,6	45,1	23,8	62,3	41,0	79,6	58,2	96,8	75,5	114,0	92,7	45,1	23,8
	SR 5/5			39,2	12,5	56,4	29,7	73,6	47,0	90,8	64,2	108,1	81,4	56,4	29,7
	SR 6/6			50,4	18,5	67,7	35,7	84,9	52,9	102,1	70,1	120,1	94,2	67,7	35,7
RE 101	SR 3/3	50,1	32,3	77,5	59,7	105,0	87,2	132,5	114,7	159,9	142,1	187,4	169,6	50,1	32,3
	SR 4/4	39,3	15,6	66,8	43,0	94,2	70,5	121,7	98,0	149,2	125,4	176,6	152,9	66,8	43,1
	SR 5/5			56,0	26,4	83,5	53,8	110,9	81,3	138,4	108,7	165,9	136,2	83,5	53,8
	SR 6/6			72,7	37,1	100,2	64,6	127,6	92,0	155,1	119,5	190,6	155,1	100,2	64,6
RE 116	SR 3/3	80,7	50,5	124,4	94,2	168,1	137,9	211,8	181,6	255,5	225,3	299,3	269,0	80,7	50,5
	SR 4/4	63,9	23,5	107,6	67,3	151,3	111,0	195,0	154,7	238,7	198,4	282,4	242,1	107,6	67,3
	SR 5/5			90,8	40,4	134,5	84,1	178,2	127,8	221,9	171,5	265,6	215,2	134,5	84,1
	SR 6/6			117,7	57,2	161,4	100,9	205,1	144,6	248,8	188,3	304,8	235,5	161,4	100,9
RE 126	SR 3/3	105,0	64,9	161,6	121,5	218,2	178,2	274,9	234,8	331,6	291,4	388,1	348,0	105,0	64,9
	SR 4/4	83,3	29,9	140,0	86,5	196,6	143,2	253,2	199,8	309,9	256,4	366,5	313,0	140,0	86,6
	SR 5/5			118,3	51,5	175,0	108,2	231,6	164,8	288,2	221,4	344,8	278,1	175,0	108,2
	SR 6/6			153,3	73,2	210,0	129,8	266,6	186,4	323,2	243,1	366,6	291,1	210,0	129,8
RE 146	SR 3/3	162,5	102,6	250,8	190,9	339,2	279,3	427,5	367,7	515,9	456,0	604,3	544,4	162,5	102,6
	SR 4/4	128,3	48,4	216,6	136,8	305,0	225,1	393,3	313,5	481,7	401,9	570,1	490,2	216,6	136,8
	SR 5/5			182,4	82,6	270,8	171,0	359,1	259,3	447,5	347,7	535,9	436,0	270,8	171,0
	SR 6/6			236,6	116,8	324,9	205,2	413,3	293,5	501,7	381,9	561,6	443,4	324,9	205,2
RE 161	SR 3/3	202,7	141,9	317,5	256,8	432,4	371,6	547,3	486,5	662,1	601,4	777,0	716,2	202,7	141,9
	SR 4/4	155,3	74,3	270,2	189,2	385,1	304,1	499,9	418,9	614,8	533,8	729,7	648,7	270,2	189,2
	SR 5/5			222,9	121,6	337,8	236,5	452,6	351,4	567,5	466,2	682,4	581,1	337,8	236,5
	SR 6/6			290,4	168,9	405,3	283,8	520,2	398,6	635,0	513,5	701,5	578,3	405,3	283,8
RE 181	SR 3/3	281,6	188,2	438,1	344,7	594,7	501,3	751,3	657,9	907,8	814,5	1064	971,0	281,6	188,2
	SR 4/4	218,8	94,3	375,4	250,9	532,0	407,5	688,5	564,0	845,1	720,6	1002	877,2	375,4	250,9
	SR 5/5			312,7	157,0	469,3	313,6	625,8	470,2	782,4	626,8	939,0	783,3	469,3	313,6
	SR 6/6			406,5	219,8	563,1	376,3	719,7	532,9	876,2	689,5	971,0	783,3	563,1	376,3
RE 201	SR 3/3	386,2	259,8	601,5	475,13	816,8	690,5	1032	905,8	1247	1121	1436	1336	386,2	259,8
	SR 4/4	299,6	131,1	514,9	46,4	730,2	561,8	945,5	777,1	1160	992,4	1376	1208	514,9	346,4
	SR 5/5			428,3	217,7	643,6	433,0	858,9	648,4	1074	863,7	1290	1079	643,6	433,0
	SR 6/6			557,0	304,3	772,3	519,6	987,6	735,0	1203	950,3	1333	1152	772,3	519,6
RE 241	SR 3/3	664,0	453,6	1037	826,2	1409	1199	1782	1571	2154	1944	2527	2316	664,0	453,6
	SR 4/4	521,8	232,3	885,4	604,8	1258	977,4	1630	1350	2003	1722	2376	2095	885,4	604,8
	SR 5/5			734,2	383,5	1107	756,0	1479	1129	1852	1501	2224	1874	1107	756,0
	SR 6/6			955,5	534,7	1328	907,2	1701	1280	2073	1653	2316	1933	1328	907,2
RE 271	SR 3/3	912,5	705,1	1452	1244	1991	1783	2530	2323	3069	2862	3608	3401	912,5	705,1
	SR 4/4	677,5	400,8	1217	940,2	1526	1479	2295	2019	2834	2558	3373	3097	1217	940,1
	SR 5/5			981,7	635,8	1751	1175	2060	1714	2599	2144	3138	2793	1521	1175
	SR 6/6			1286	871,0	1825	1410	2364	1954	2903	2489	3353	3041	1825	1410
RE 331	SR 3/3	1626	1108	2538	2020	3450	2931	4361	3843	5273	4755	6184	5666	1626	1108
	SR 4/4	1257	565,8	2168	1477	3080	2389	3992	3301	4903	4212	5815	5123	2168	1477
	SR 5/5			1799	935,2	2711	1847	3622	2759	4534	3670	5445	4582	2711	1847
	SR 6/6			2341	1305	3253	2216	4165	3128	5076	4040	5666	4582	3253	2216
RE 421	SR 3/3	2999	2014	4670	3685	6340	5356	8011	7026	9682	8697	11353	10368	2999	2014
	SR 4/4	2327	1014	3998	2685	5669	4356	7340	6027	9011	7698	9369	9369	3998	2685
	SR 5/5			3327	1685	4998	3356	6669	5027	8340	6698	8369	8369	4998	3356
	SR 6/6			4327	2357	5997	4028	7668	5698	8369	7369	9369	8369	5997	4028

Torque by air

Torque by springs

VDI\VDE-3854

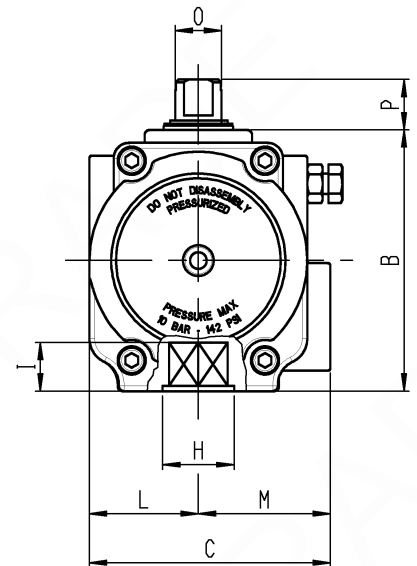
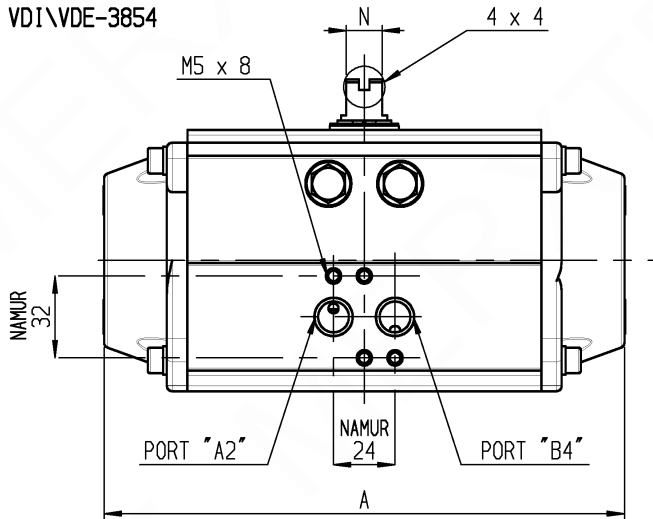

VDI\VDE-3854

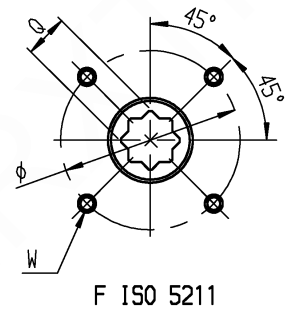
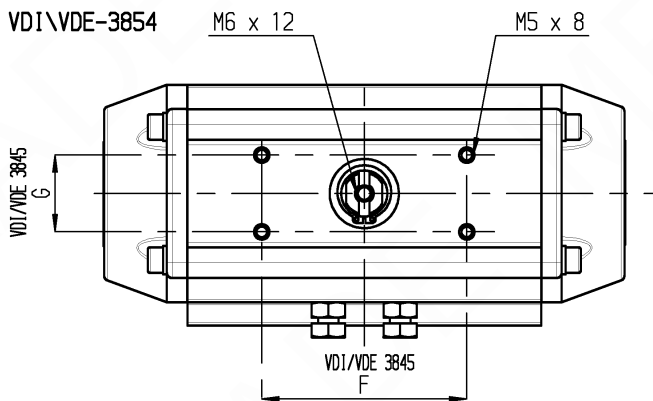

POSITION	TYPE															
	RE 043	RE 051	RE 064	RE 076	RE 086	RE 101	RE 116	RE 126	RE 146	RE 161	RE 181	RE 201	RE 241	RE 271	RE 331	RE 421
<b>A</b>	141	138	155	203	239	261	304	333	398	424	482	528	604	684	850	940
<b>B</b>	62	69	86	102	112	127	145,5	157,5	177	196	220	246	298	332	414	542
<b>C</b>	63,5	75	86	94	104	120	133,5	144,5	164,5	182	203,5	222	300	352	400	528
<b>VDI/VDE 3845 F x G</b>	80 x 30 50 x 25	80 x 30					80 x 30 130 x 30			130 x 30						200 x 50
<b>L</b>	27	33,5	38	42,5	49	55	63,5	69,5	80,5	89	99,5	110	150	176	190	234
<b>M</b>	36,5	41,5	48	51,5	55	65	70	75	84	93	104	112	150	176	210	294
<b>Port A Port B DIN 259</b>	1/8" GAS-NPT			1/4" GAS-NPT									1/2" GAS-NPT			
<b>N x O</b>	8 x 12			14 x 18			27 x 36			32 x 42		42 x 60	55 x 80			
<b>P</b>	20						30			50						80
<b>Q x I</b>	9 x 10 11 x 13	9 x 10 11 x 13	9 x 10 11 x 13 14 x 16	11 x 13 14 x 16 17 x 20	14 x 16 17 x 20	14 x 16 17 x 20 22 x 25	17 x 20 22 x 25	17 x 20 22 x 25 27 x 29	22 x 25 27 x 29	22 x 25 27 x 29	27 x 29 36 x 39	27 x 29 36 x 39	36 x 39 46 x 50	36 x 39 46 x 50	*46 x 50 55 x 60	*55 x 60 75 x 80
<b>F ISO 5211</b>	F04	F04	F05/07	F05/07	F05/07	F07/10	F07/10	F07/10	F10/12	F10/12	F10/12	F14	F14	F16	F16/25	F25/30
<b>Optional</b>	F03/05	F03/05	F3/5/7			F5/7/10		F7/10/12			F14	F10/12	F(12)/16	F(12)/16		F(16)
<b>Volume DE</b>	0,180 lt	0,300 lt	0,500 lt	0,700 lt	1,000 lt	1,800 l	2,900 lt	3,700 lt	6,100 lt	7,900 lt	11,2 lt	14,4 lt	19,2 lt	32,2 lt	62,8 lt	131 lt
<b>Volume SE</b>	0,072 lt	0,120 lt	0,200 lt	0,280 lt	0,400 lt	0,720 l	1,160 lt	1,480 lt	2,440 lt	3,160 lt	4,480 lt	5,760 lt	7,680 lt	12,9 lt	25,1 lt	52,4 lt

POSITION	F ISO 5211											
	F03	F04	F03/05	F05	F05/07	F5/7/10	F07/10	F10/12	F14	F16	F25	F30
<b>Ø (W)</b>	Ø 36 (M5x8)	Ø 42 (M5x8)	Ø 36 (M5x8) Ø 50 (M6x9)	Ø 50 (M6x9)	Ø 50 (M6x9) Ø 70 (M8x12)	Ø 50 (M6x9) Ø 70 (M8x12) Ø 102 (M10x15)	Ø 70 (M8x12) Ø 102 (M10x15)	Ø 102 (M10x15) Ø 125 (M12x18)	Ø 140 (M16x24)	Ø 165 (M20x30)	Ø 254 (M16x24) N°8 FORI	Ø 298 (M20x35) N°8 FORI
<b>H</b>	25	30	25	35	35 (RE 086=40)	40	55	85 (RE 161=75)	100	130	200	200



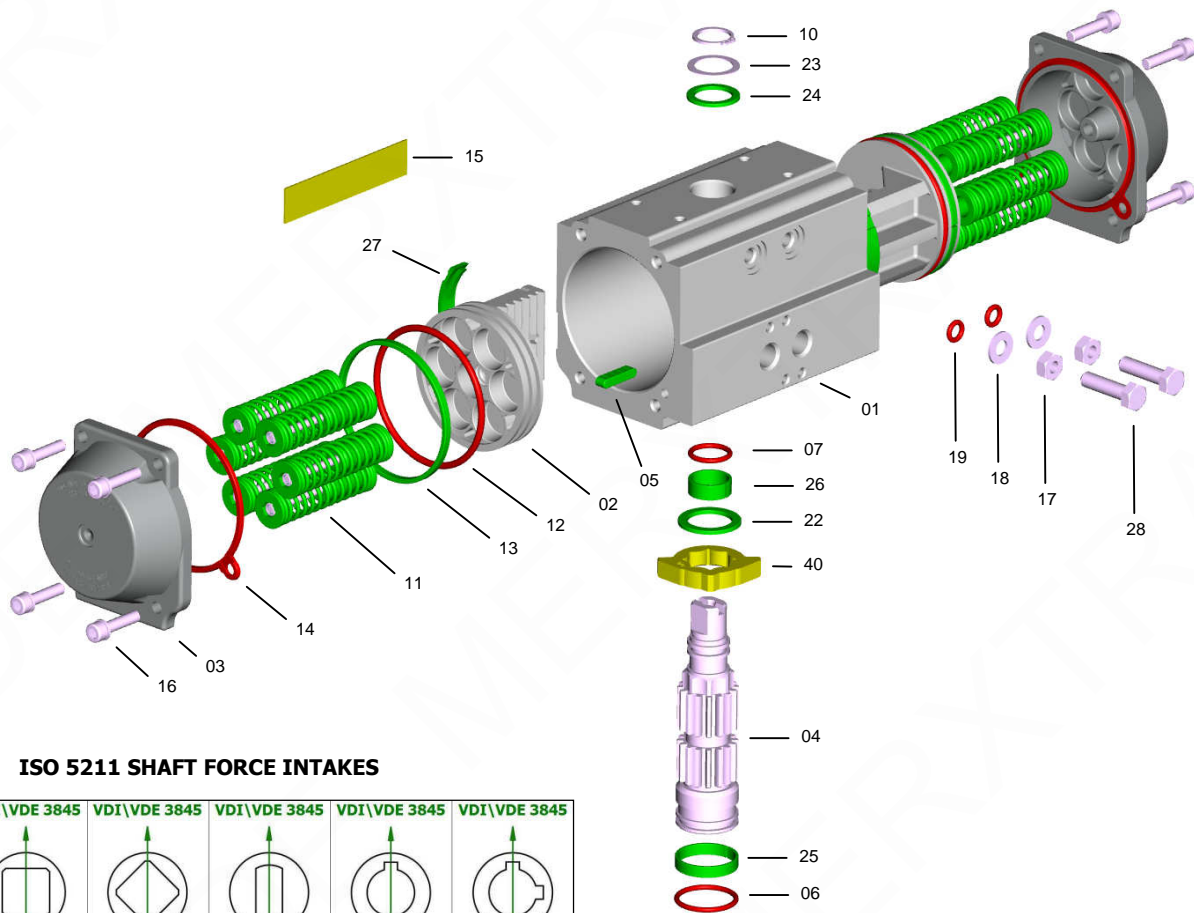

**ISO 5211 SHAFT FORCE INTAKES**

VDI\VDE 3845	VDI\VDE 3845	VDI\VDE 3845	VDI\VDE 3845	VDI\VDE 3845	VDI\VDE 3845
STANDARD ALPHAIR S = L/D	L	D	H	V	W

PART	QUANTITY	DESCRIPTION	MATERIAL	SPECIFICATION	PROTECTION
1	1	Body	Extruded aluminium alloy	EN AW 6063 T6	A - N - TF
2	2	Piston	Aluminium alloy	EN AB 46100 T6	A
3	2	Cover	Aluminium alloy	EN AB 46100 T6	N - V - TF
4	1	Shaft	Carbon steel Stainless Steel – optional	ASTM A-105 AISI 304 (A2) AISI 316 (A4)	N
5 *	2	Antiejection key	Acetalic resin – PA66 – PA66 – LEXAN		
6 *	1	Lower shaft O-Ring	NBR – FPM\FKM – Silicone – Silicone		
7 *	1	Upper shaft O-Ring	NBR – FPM\FKM – Silicone – Silicone		
10 *	1	Seeger ring	Carbon steel		N
11	0 ... 12	Spring cartridge	Carbon steel, PA 66, Stainless Steel	C-98	V
12 *	2	Piston O-Ring	NBR – FPM\FKM – Silicone – Silicone		
13 *	2	Piston head bearing	Acetalic resin – PA66 – PA66 – LEXAN		
14 *	2	Cover gasket	NBR – FPM\FKM – Silicone – Silicone		
15	1	Nameplate	Aluminium		
16	4 + 4	Cover fastening screw	Stainless Steel	AISI 304 (A2)	
17	2	Nut	Stainless Steel	AISI 304 (A2)	
18	2	Washer	Stainless Steel	AISI 304 (A2)	
19 *	2	O-Ring	NBR – FPM\FKM – Silicone – Silicone		
22 *	1	Gear antifriction washer	Acetalic resin – PA66 – PA66 – LEXAN		
23 *	1	Shaft thrust washer	Stainless Steel	AISI 304 (A2)	
24 *	1	Shaft antifriction washer	Acetalic resin – PA66 – PA66 – LEXAN		
25 *	1	Lower shaft pilot ring	Acetalic resin – PA66 – PA66 – LEXAN		
26 *	1	Upper shaft pilot ring	Acetalic resin – PA66 – PA66 – LEXAN		
27 *	2	Piston bearing	Acetalic resin – PA66 – PA66 – LEXAN		
28	2	Adjusting gear screw	Stainless Steel	AISI 304 (A2)	
40	1	Adjusting gear	Stainless Steel	AISI 316 (A4)	

\* SPARE PARTS SET: Standard, Special HIGH Temperatures, Special LOW Temperatures, Special EXTRA LOW Temperatures

**PROTECTIONS**

A = Anodizing N = chemical Nickel-plating V = Painting TF = Anodizing+PTFE

[www.merxtrade.com](http://www.merxtrade.com)

# COATINGS – MATERIAL TREATMENTS

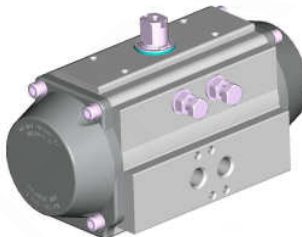
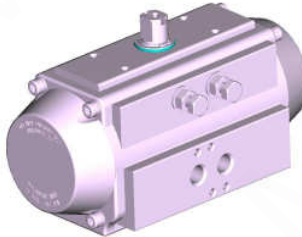
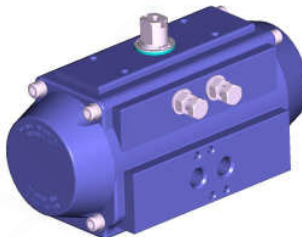
		DESCRIPTION				APPLICATION FIELD
		Body	Covers	Pistons	Shaft	
	<b>AV</b> standard	Anodizing	Polyester painting	Anodizing	High phosphorous nickel-plating (12%) opt. AISI 304 (A2) opt. AISI 316 (A4)	- Industry, general use.
	Colour	Gray	Gray	Brown	Polished steel	
	Thickness	25 µ	60/80 µ	15 µ	20 µ	
	<b>NN</b>	High phosphorous nickel-plating (12%)	High phosphorous nickel-plating (12%)	Anodizing	High phosphorous nickel-plating (12%) opt. AISI 304 (A2) opt. AISI 316 (A4)	- Industry, general use. - Caustic soda. - Detergents. - Low alkaline solutions.
	Colour	Polished steel	Polished steel	Brown	Polished steel	
	Thickness	20 µ	20 µ	15 µ	20 µ	
	<b>TF TF</b>	Anodizing + PTFE coating	Anodizing + PTFE coating	Anodizing	High phosphorous nickel-plating (12%) opt. AISI 304 (A2) opt. AISI 316 (A4)	- Industry, general use. - Low alkaline and low acid solutions. - Marine environments. - High temperatures.
	Colour	Blue	Blue	Brown	Polished steel	
	Thickness	Anodizing 25 µ PTFE 15 µ	Anodizing 15 µ PTFE 15 µ	15 µ	20 µ	

## ANODIZING

Anodizing is an electrolytic process that produces anodic coating on aluminum, called alumine, with high thickness. Alumine is one of the most hard known materials, with resistance values up to 400-600 HV (45-65 HRC); properties and features of Anodizing (alumine thickness 25 micron) are well know and appreciated both for mechanical and chemical resistance.

- **Best friction and corrosion resistance, best surface hardness, good thermic and electrical insulation.**

## ELECTROLESS NICKEL-PLATING

Chemical nickel-plating is an electroless coating process that gives nickel layers at extremely constant thickness also on sharp angles, blind-holes, threads and grooves recess. During the process, nickel is combined with phosphor at a percentage of 12% (high-phosphor). The obtained surface hardness is about 400-480 HV (45-55 HRC).

- **Best friction and corrosion resistance, best surface hardness, best external appearance similar to S.S., increased resistance to alcali and detergents in sanitary and food applications.**

## POLYESTER PAINTING

Polyester painting is obtained through powder coatings on polarized parts, by means of light differences in electrical potentials. After applications, parts are baked in order to polymerize and let the painting be spread to avoid micro-porosity. The best elasticity can be obtained at 60/80 micron thickness; a satisfactory adhesion can be assured by sandblasting or brushing, and by special degreasing baths of the rough pieces to be treated.

- **Better corrosion resistance, protection against crashes, better external appearance and several available colours, resistance to chemicals.**

## ANODIZING + PTFE COATING

As further improvement of the hard anodising treatment on aluminium alloys, protective coatings made of PTFE are used; this material is known for its particular chemical and physical features. On these double treated surfaces, oxide hardness and low roughness (internal slipping parts) is summed to the chemical resistance and the excellent qualities as a thermic barrier of PTFE (external surface, subject to corrosion).

- **Better corrosion resistance, protection against high temperatures and crashes, extreme resistance to chemicals and in marine environments.**

## AISI 304 (A2) OR AISI 316 (A4) STAINLESS STEEL SHAFT - OPTIONAL

AISI 304 (A2) and AISI 316 (A4) Stainless Steel shafts, with their great corrosion resistance, are recommended for special applications such as: marine and chemical environments, food and pharmaceutical industry, high temperature applications.



Via Molino Emili, 16 - 25030 MACLODIO (BS) Italy - Tel. +39 030 97 86 61/2- Fax +39 030 97 86 63  
www.alphair.it - www.alphapompe.it

Tous droits réservés - Annule et remplace toutes les versions précédentes - Les données sont sujettes à changement sans préavis - Non garantie l'exactitude

COMPANY WITH  
QUALITY SYSTEM  
CERTIFIED BY DNV GL  
= ISO 9001 =



www.merxtrade.com

Information provided as an indication and subject to possible modification. Colours and details can be different then shown in data sheets or pictures.  
Merxtrade BV has no liability for any damages by use off any information displayed on these pages.